

# CORNERSTONE WINDOWS & DOORS

ALUMINUM SYSTEMS COLLECTION  
GLASS WALLS • SLIDING • BIFOLD



CORNERSTONE  
WINDOWS & DOORS

# ALUMINUM WALL SYSTEMS

Engineered for expansive openings, seamless transitions, and effortless operation.

Product Line	Description	Key Features
BIFOLD DOORS	Folding patio door systems that create wide, unobstructed openings.	Multi-point locking system Bottom-loaded steel hardware Low / integrated thresholds Durable powder-coated finishes
SLIDING DOORS	Multi-track and lift & slide systems for expansive openings.	Aeris Series (slim profiles), Vision Series (oversized panels), Lift & Slide (air-tight insulation).
GLASS WALL SYSTEMS	Large-panel glass walls for panoramic views.	Minimal aluminum profiles, oversized panels, glass options, energy efficiency, incredible views

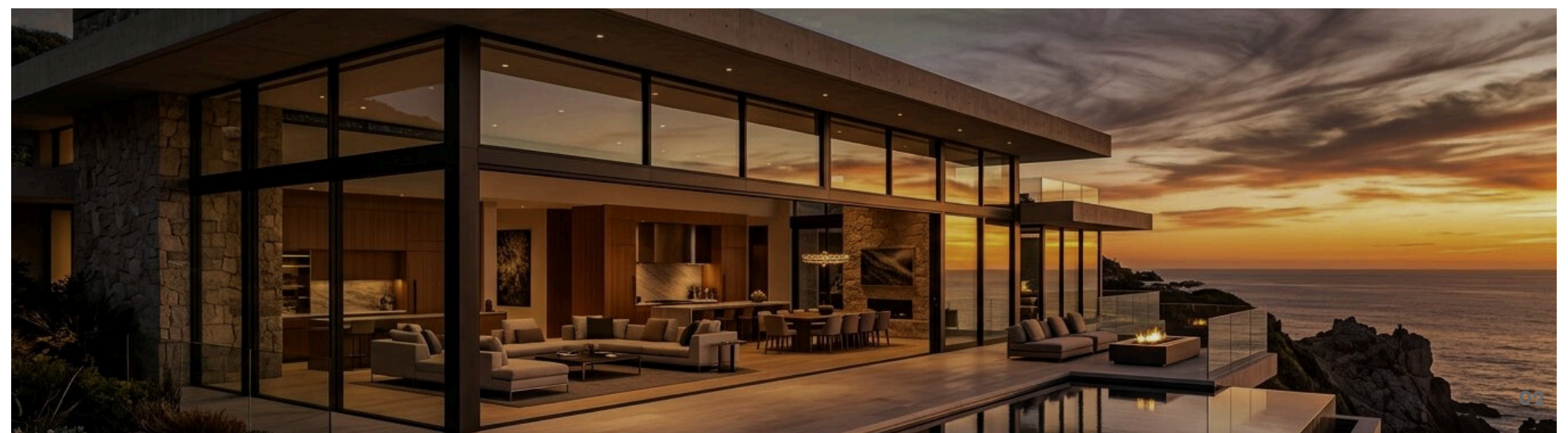

# GLASS WALL SYSTEMS

Seamless living. Limitless views.  
Minimal frames. Maximum glass.

## FEATURES

- Ultra-slim profiles
- Thermal break system
- Energy-efficient
- Corner configurations
- Custom sizes

## APPLICATIONS

RESIDENTIAL • HOSPITALITY • COMMERCIAL

# SPECIFICATIONS - GLASS WALL SYSTEMS



Designed as a full-height glass wall system with recessed top and bottom, this solution is built on advanced German engineering. It enables larger panel sizes, reduced sightlines, and superior transparency while maintaining structural performance.

There are multiple systems that are designed for various applications, from high-rises to smaller residential one-story homes. Each system brings unique characteristics and delivers the same result: panoramic views, elegant application, no maintenance, sturdy structure, and unbeatable thermal efficiency

## GLASS OPTIONS & PERFORMANCE



Black Tempered



Super Light Tempered



Ford Blue Coated



EU Gray Coated



Bule Star Gray Coated



Dark Low-E



Light Low-E



Matte

Choose from multiple insulated glass options designed for energy efficiency, clarity, comfort, and modern aesthetics, along with various tints for the custom look.

## STANDARD POWDER COAT OPTIONS

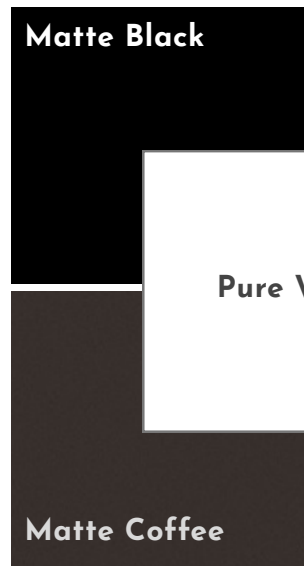

Durable powder-coated finishes provide superior resistance to weathering, fading, and corrosion. Available in a range of standard RAL colors with custom finishes upon request.

# GLASS WALL DETAIL PROFILE

High-performance glass wall systems designed for modern architecture. Engineered for strength, efficiency, and seamless integration across a wide range of commercial and residential applications.



## UNITIZED GLASS WALL

Modern glass wall systems engineered for performance, flexibility, and design precision. Available in multiple configurations with advanced thermal performance and durable aluminum construction.

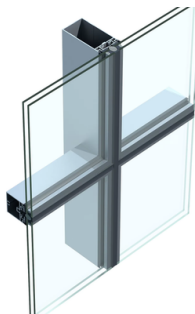

## STICK GLASS WALL

Site-built system offering flexibility in design and installation, ideal for custom layouts and complex architectural conditions.

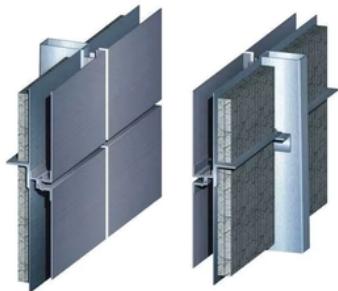

## ALUMINUM PLATE GLASS WALL

Lightweight, durable aluminum panels designed for strength, weather resistance, and clean modern façade applications.

# VISION SERIES SLIDING DOORS

---

## KEY TECHNICAL FEATURES

**Thermally Broken Frames**  
Improves insulation and energy efficiency.

**Large-Scale Openings**  
Supports oversized glass panels.

**Slim Profiles**  
Maximizes glass and natural light.

**Low-E Glass**  
Enhances energy performance.

**Warranty Coverage**  
Long-term reliability.

**Nationwide Support**  
Delivery and installation assistance.

# SPECIFICATIONS - VISION SLIDING DOOR SYSTEMS



<b>U-Value</b>	<b>0.3</b>		
<b>Air Leakage</b>	<b>0.3</b>		
<b>Water Tightness</b>	<b>400pa</b>	<b>Sighline Width</b>	<b>Frame: 2" Panel: 2.25" (lock) / 1.4" (overlap)</b>
<b>Wind Resistance</b>	<b>4000pa</b>	<b>Max size</b>	<b>Weight: 1,100 lbs Size: 8'W x 16' H</b>
<b>Sound Insulation</b>	<b>36dB</b>	<b>Security</b>	<b>Multi - Point Hook Lock</b>
<b>Alum Profile &amp; Thickness</b>	<b>6063-T5 Al (2.0mm</b>	<b>Colours</b>	<b>Powder Coat: Black / White / RAL</b>
<b>Glazing</b>	<b>1" Dual Pane, Tempered, Argon, Low-E</b>		
<b>Profile Depth</b>	<b>Frame: 5.4" (2 panel) Panel: 2"</b>		

## GLASS OPTIONS & PERFORMANCE



Black Tempered



Super Light Tempered



Ford Blue Coated



EU Gray Coated



Bule Star Gray Coated



Dark Low-E



Light Low-E



Matte

Choose from multiple insulated glass options designed for energy efficiency, clarity, comfort, and modern aesthetics, along with various tints for the custom look.

## STANDARD POWDER COAT OPTIONS



Matte Black



Pure White



Matte Coffee



Durable powder-coated finishes provide superior resistance to weathering, fading, and corrosion. Available in a range of standard RAL colors with custom finishes upon request.

# SPECIFICATIONS

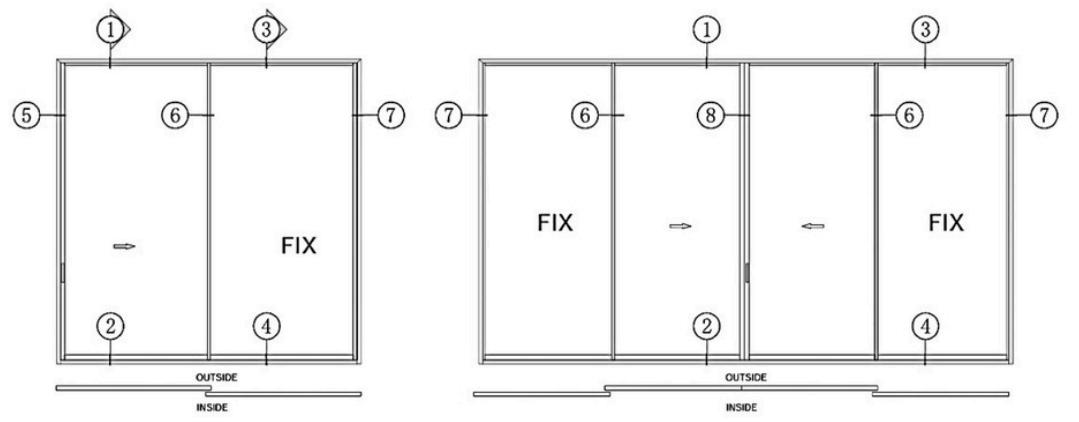
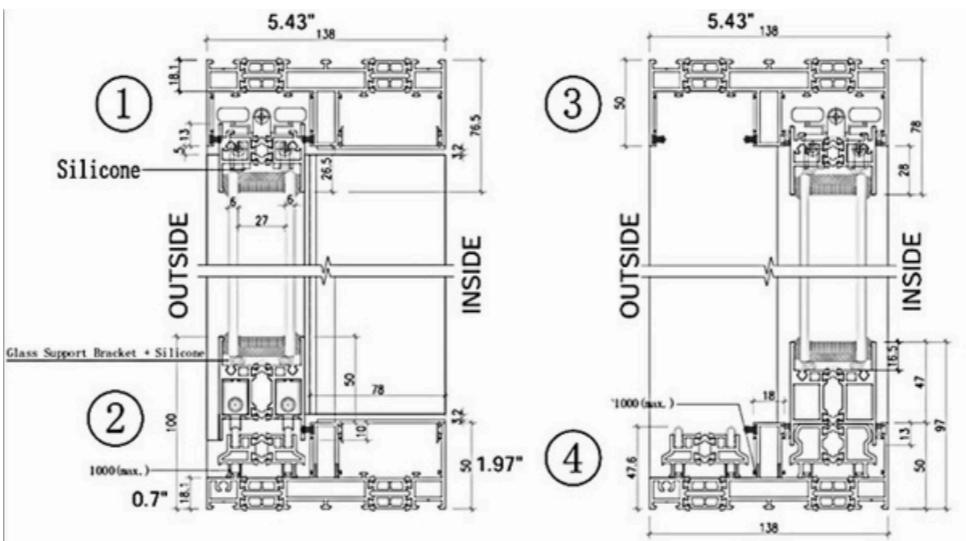

## HARDWARE OPTIONS

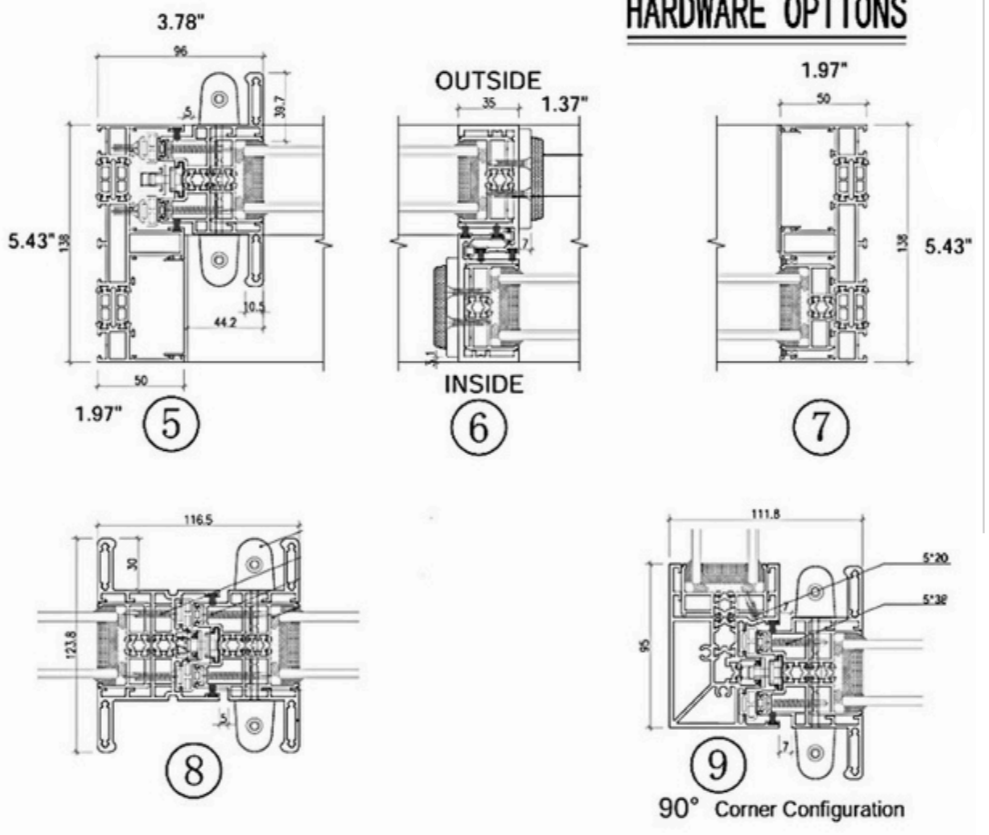

# AERIS SERIES SLIDING DOORS

---

## KEY TECHNICAL FEATURES

**Thermally Broken Frames**  
Improves insulation and energy efficiency.

**Large-Scale Openings**  
Supports oversized glass panels.

**Slim Profiles**  
Maximizes glass and natural light.

**Low-E Glass**  
Enhances energy performance.

**Warranty Coverage**  
Long-term reliability.

**Nationwide Support**  
Delivery and installation assistance.

---



# SPECIFICATIONS - ARIES SLIDING DOOR SYSTEMS



<b>U-Value</b>	<b>0.3</b>
<b>Air Leakage</b>	<b>0.3</b>
<b>Water Tightness</b>	<b>400pa</b>
<b>Wind Resistance</b>	<b>4000pa</b>
<b>Sound Insulation</b>	<b>36dB</b>
<b>Alum Profile &amp; Thickness</b>	<b>6063-T5 Al (2.0mm)</b>
<b>Glazing</b>	<b>1" Dual Pane, Tempered, Argon, Low-E</b>
<b>Profile Depth</b>	<b>Frame: 4.25" (2 panel) Panel: 1.5"</b>

<b>Sighline Width</b>	<b>Frame: 2" Panel: 2.25" (lock)/ONLY 1" (overlap)</b>
<b>Max size</b>	<b>Weight: 1,100 lbs Size: 8'W x 12' H</b>
<b>Security</b>	<b>Multi - Point Hooks Lock</b>
<b>Colours</b>	<b>Powder Coat: Black / White / Custom RAL</b>

## GLASS OPTIONS & PERFORMANCE



Black Tempered



Super Light Tempered



Ford Blue Coated



EU Gray Coated



Bule Star Gray Coated



Dark Low-E



Light Low-E



Matte

Choose from multiple insulated glass options designed for energy efficiency, clarity, comfort, and modern aesthetics, along with various tints for the custom look.

## STANDARD POWDER COAT OPTIONS

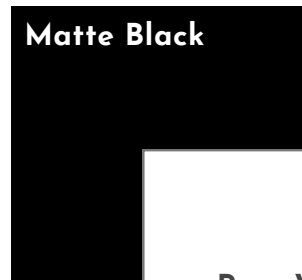

Durable powder-coated finishes provide superior resistance to weathering, fading, and corrosion. Available in a range of standard RAL colors with custom finishes upon request.

# SPECIFICATIONS

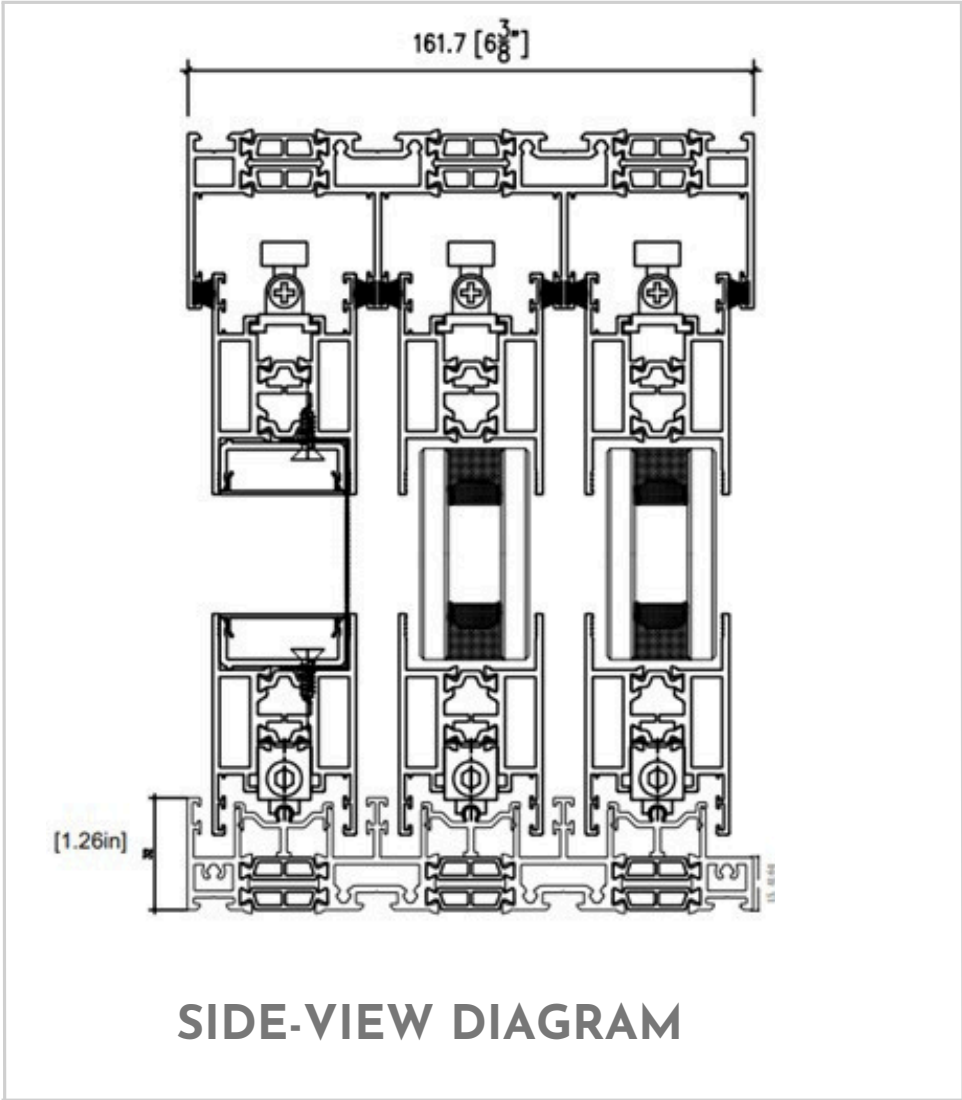

**SECTION VIEW**

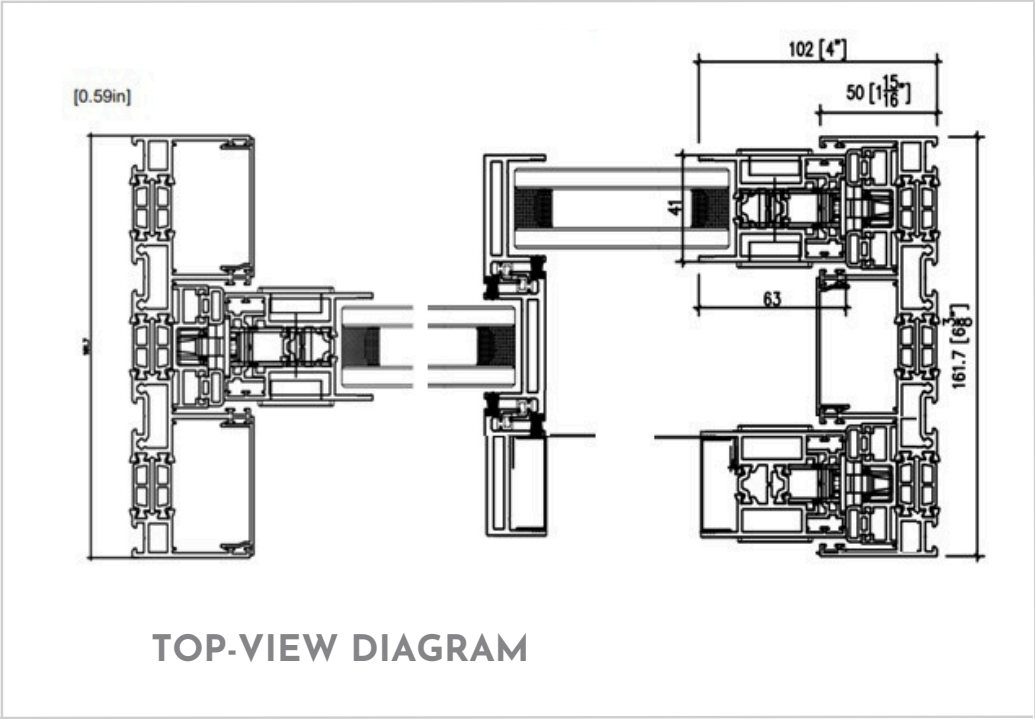



# LIFT- & -SLIDE SLIDING DOORS

---

## KEY TECHNICAL FEATURES

### **Thermally Broken Frames**

Improves insulation and energy efficiency.

### **Large Panel Capacity**

Supports oversized panels up to 770 lbs

### **High Weather Performance**

Engineered for air, water, and wind resistance.

### **Multi-Point Locking**

Enhanced security and structural sealing.

### **Advanced Glazing**

Double / triple glazing for thermal and acoustic comfort.

### **Smooth Lift & Slide Operation**

Effortless movement with precision hardware

# SPECIFICATIONS - LIFT & SLIDE DOOR SYSTEM



**U-Value** 0.3

**Air Leakage** 0.1

**Water Tightness** 720pa Level 6

**Wind Resistance** 40000pa Level 7

**Sound Insulation** 36dB Level 7

**Alum Profile & Thickness** 6063-T5 Al (2.0mm)

**Glazing** 1" Dual Pane, Tempered, Argon, Low-E

**Profile Depth** Frame: 6.3" / Panel: 2.5"

**Sighline Width** Frame: 2" / Panel: 3"

**Max size** Weight: 770 lbs / 8' W x 10' H

**Security** Multi - Point HookS Lock

**Colours** Powder Coat: Black / White / Custom RAL

## GLASS OPTIONS & PERFORMANCE



Black Tempered



Super Light Tempered



Ford Blue Coated



EU Gray Coated



Bule Star Gray Coated



Dark Low-E



Light Low-E



Matte

Choose from multiple insulated glass options designed for energy efficiency, clarity, comfort, and modern aesthetics, along with various tints for the custom look.

## STANDARD POWDER COAT OPTIONS

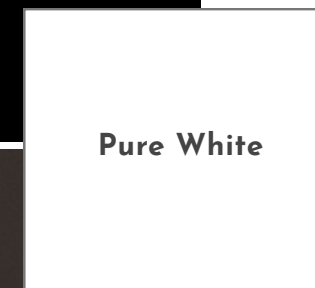
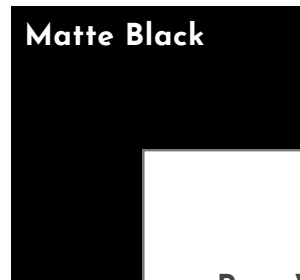

Durable powder-coated finishes provide superior resistance to weathering, fading, and corrosion. Available in a range of standard RAL colors with custom finishes upon request.

## TRACK, FRAME & FINISH DETAILS

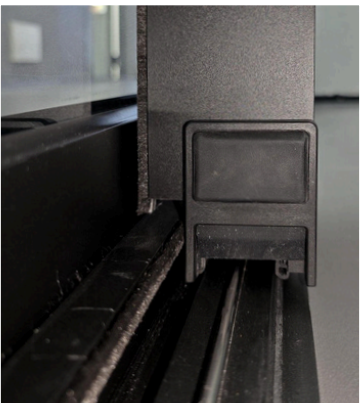

Architectural-grade aluminum track and frame systems engineered for smooth operation, structural durability, and refined modern aesthetics. Precision detailing and premium surface finishes ensure long-term performance in demanding environments.

## LIFT & SLIDE MECHANISM

European-engineered lift & slide systems use a precision roller mechanism that raises and lowers panels for effortless operation. When closed, compression seals create a tight barrier against air and water infiltration.

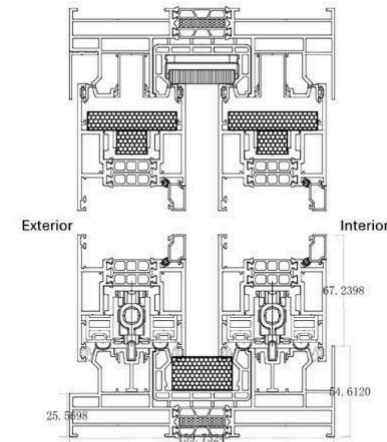

## SECTION VIEW

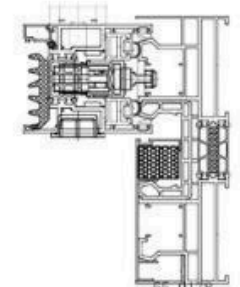
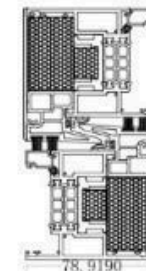
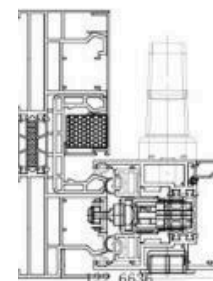

## SYSTEM PROFILE SECTIONS

# VISION SERIES BIFOLD DOOR

## KEY TECHNICAL FEATURES

**Thermal Break Technology**  
Improves energy efficiency.

**Ultra Slim Profiles**  
35mm frame / 45mm panel.

**High Performance Sealing**  
Air, water, and wind resistance.

**Insulated Glazing**  
Argon-filled double glazing.

**Compact Frame System**  
75mm frame depth.

**Smooth Folding System**  
Effortless operation.

**Multi-Point Lock System**  
Enhanced security.

**Aluminum Construction**  
Durable 6063-T5 profiles.

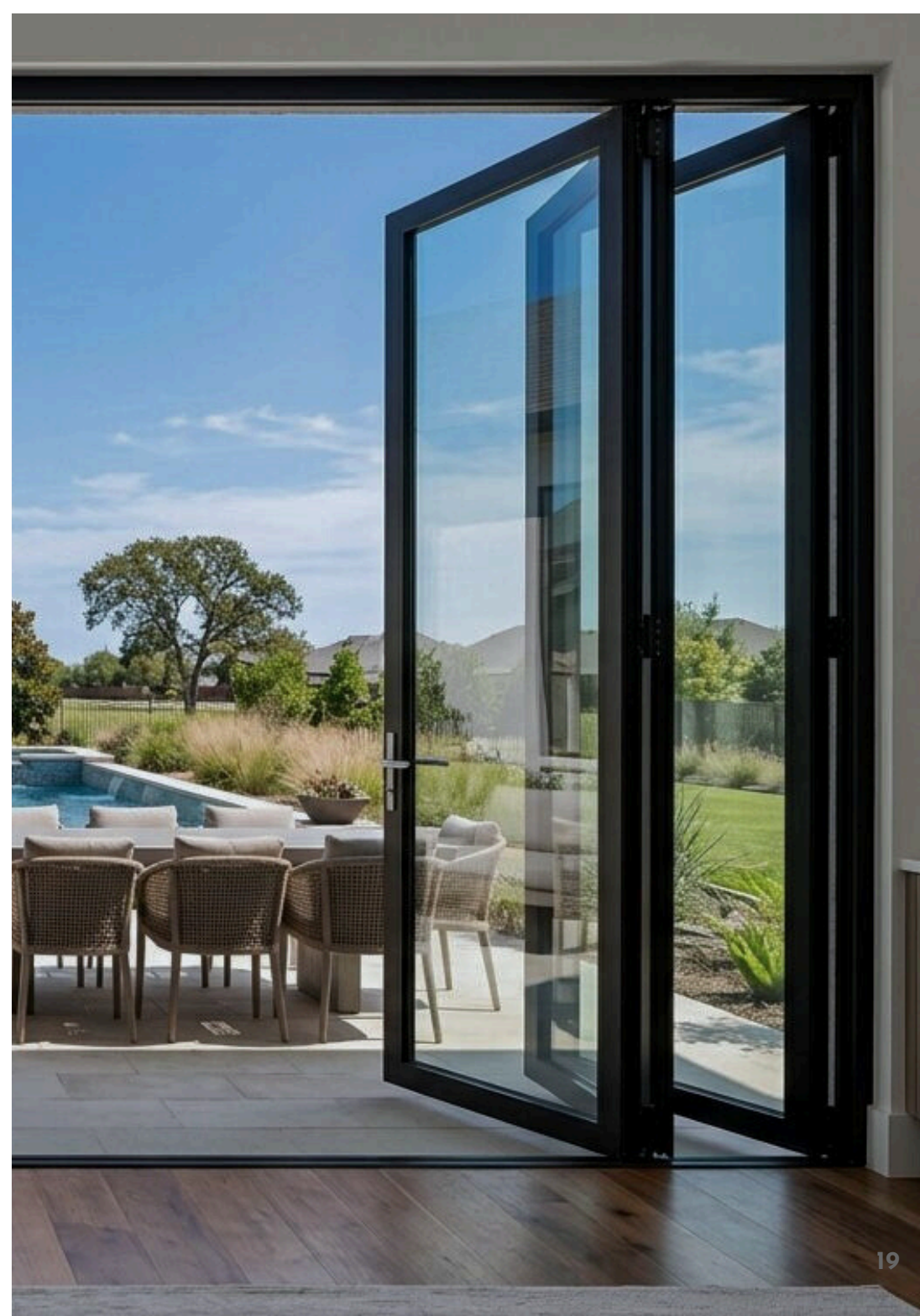

# SPECIFICATIONS - VISION BIFOLD DOOR SYSTEM

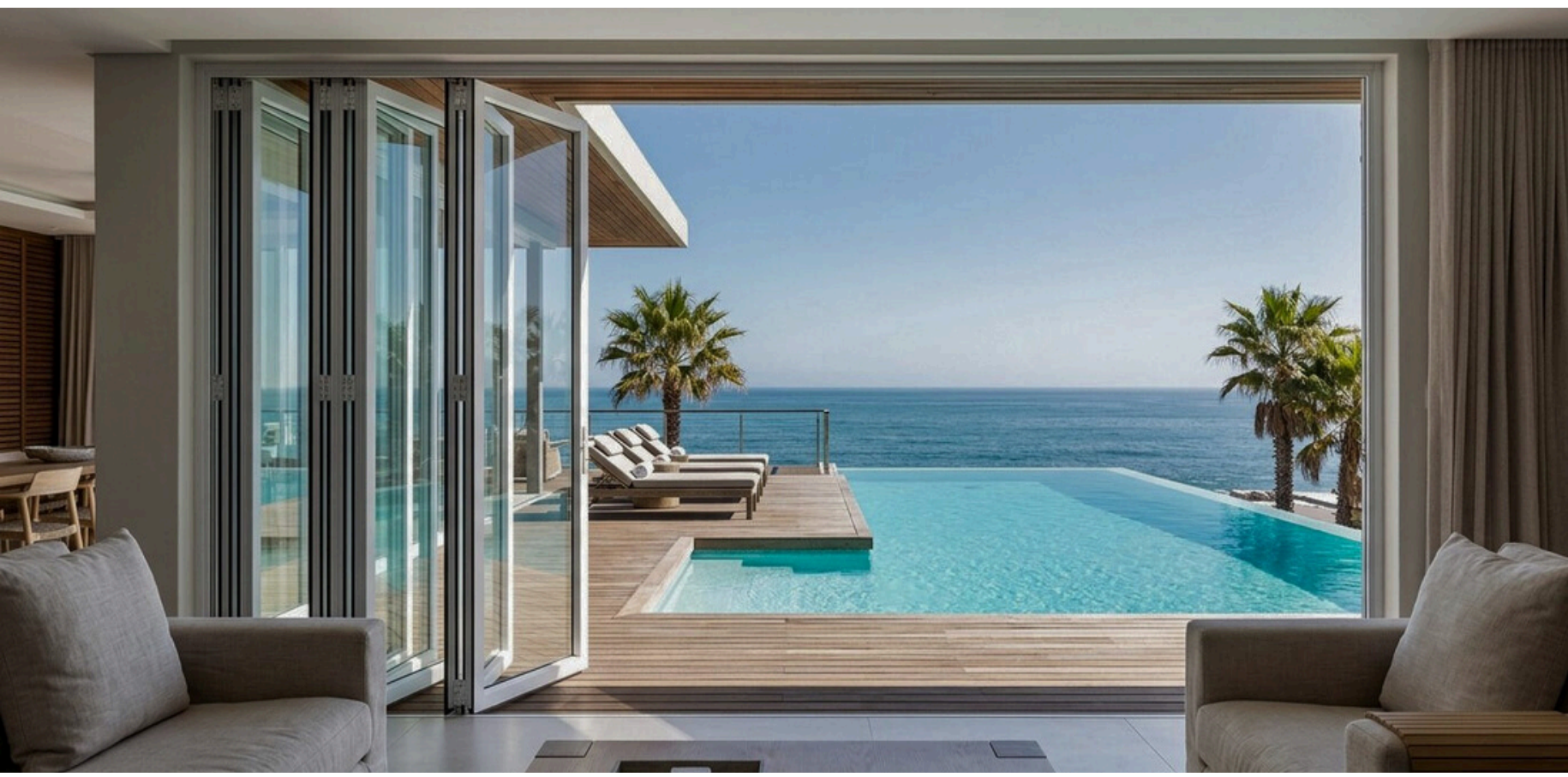

<b>U-Value</b>	<b>0.3</b>
<b>Air Leakage</b>	<b>0.3</b>
<b>Water Tightness</b>	<b>550pa Level 6</b>
<b>Wind Resistance</b>	<b>40000pa Level 7</b>
<b>Sound Insulation</b>	<b>36dB Level 7</b>
<b>Alum Profile &amp; Thickness</b>	<b>6063-T5 Al 2.0mm</b>
<b>Glazing</b>	<b>1" Dual Pane, Tempered, Argon, Low-E</b>
<b>Profile Depth</b>	<b>Frame: 75mm / Panel: 65mm</b>

<b>Sighline Width</b>	<b>Frame: 35mm / Panel: 45mm</b>
<b>Max size</b>	<b>Weight: 300 lbs / 3ft Wx 11.8ft H</b>
<b>Security</b>	<b>Multi - Point (3) Lock</b>
<b>Colours</b>	<b>Powder Coat: Black / White / Custom RAL</b>

# ENGINEERED FOR ARCHITECTURAL PERFORMANCE

VISION BIFOLD DOOR

PRECISION-CRAFTED ALUMINUM BIFOLD SYSTEM DESIGNED FOR SEAMLESS INDOOR-OUTDOOR LIVING, STRUCTURAL STRENGTH, AND LONG-TERM DURABILITY.



## Integrated Multi-Point Lock

Concealed multi-point locking system provides enhanced security while maintaining a clean, architectural profile.



## Heavy-Duty Hinges

Reinforced hinge system ensures structural stability and smooth, controlled panel operation.



## Retractable Latch System

Smooth operation retractable latch system allowing one handed opening and closing of the entire door system.



## Smooth Glide System

Precision-engineered roller system ensures smooth, quiet operation with long-term performance and reliability.

# DESIGNED FOR SEAMLESS LIVING

ENGINEERED TO CREATE FLUID TRANSITIONS BETWEEN INTERIOR AND EXTERIOR SPACES, COMBINING REFINED AESTHETICS WITH PRECISION HARDWARE AND EFFORTLESS OPERATION.



## Slim Sightlines

Refined frame and panel profiles maximize glass area for uninterrupted views and natural light.

## System Profile

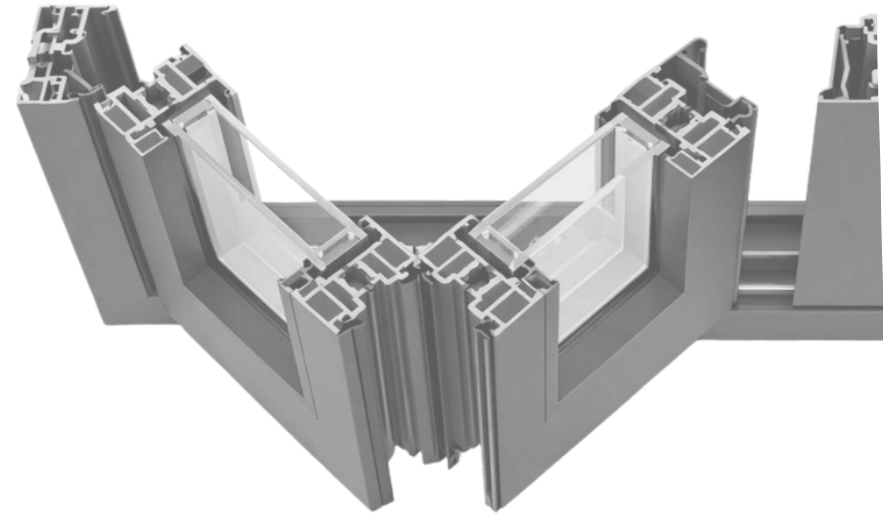

## Thermally Engineered Profiles

Multi-chamber aluminum construction with thermal breaks improves energy efficiency in all climates.

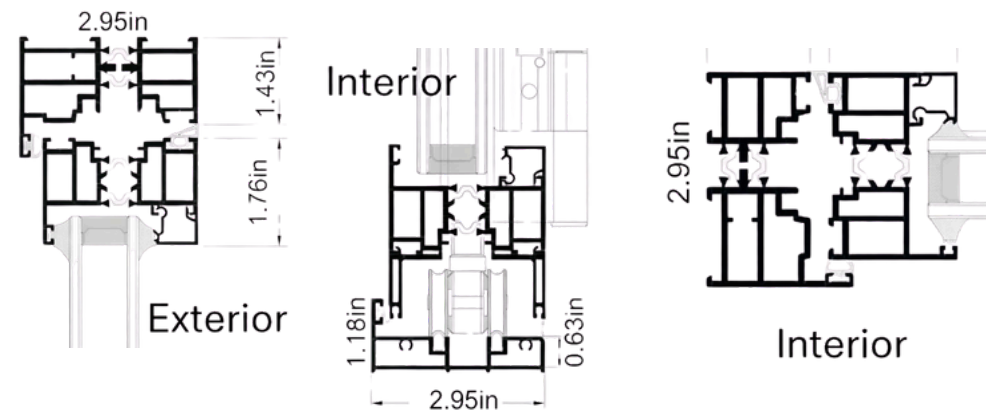

## GLASS OPTIONS & PERFORMANCE



Black Tempered



Super Light Tempered



Ford Blue Coated



EU Gray Coated



Blue Star Gray Coated



Dark Low-E



Light Low-E



Matte

Choose from multiple insulated glass options designed for energy efficiency, clarity, comfort, and modern aesthetics, along with various tints for the custom look.

## STANDARD POWDER COAT OPTIONS

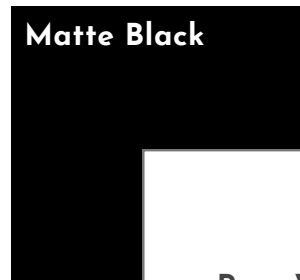

Matte Black



Pure White



Matte Coffee



RAL Colors

Durable powder-coated finishes provide superior resistance to weathering, fading, and corrosion. Available in a range of standard RAL colors with custom finishes upon request.

# CONFIGURATION FLEXIBILITY

ENGINEERED TO CREATE FLUID TRANSITIONS BETWEEN INTERIOR AND EXTERIOR SPACES, COMBINING REFINED AESTHETICS WITH PRECISION HARDWARE AND EFFORTLESS OPERATION.

## 2 Panel

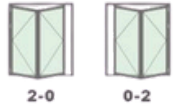

## 3 Panel

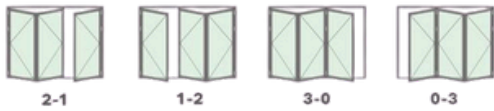

## 4 Panel

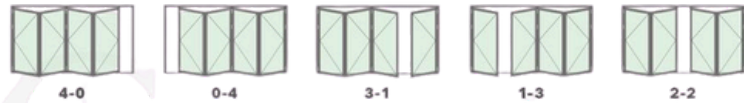

## 5 Panel

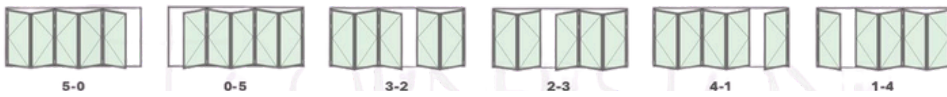

## 6 Panel

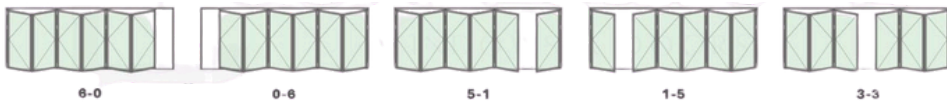

## 7 Panel



## 8 Panel

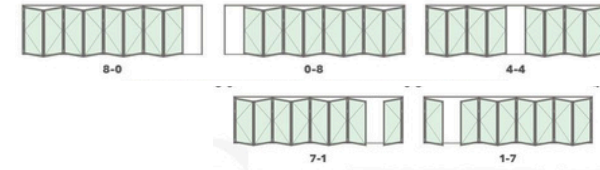

## 9 Panel

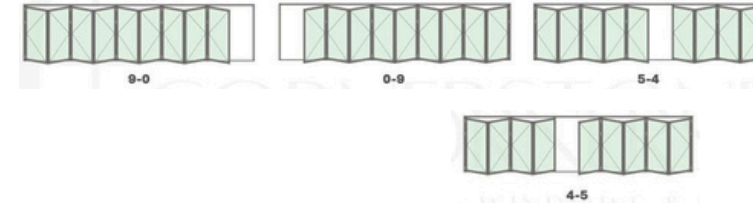

## 10 Panel

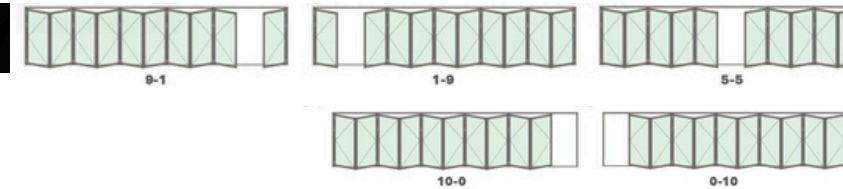

Allows inward or outward folding with multiple stacking configurations to suit any architectural layout.



CORNERSTONE  
WINDOWS & DOORS

DESIGNED FOR MODERN LIVING  
ENGINEERED FOR PERFORMANCE



**PHONE**

(855) 630-3982

CORNERSTONE  
WINDOWS & DOORS

**SALES INQUIRIES** EXT 1  
**CLIENT SUPPORT** EXT 2  
**PROJECT UPDATE** EXT 3

**Start Your Project Today**  
→ [www.cornerstonewd.com](http://www.cornerstonewd.com)

**EMAIL**

[info@cornerstonewd.com](mailto:info@cornerstonewd.com)